

All Rights Reserved.

Confidential



Department of Examinations - Sri Lanka

G.C.E. (A/L) Examination - 2017

20 - Information and Communication Technology

Marking Scheme

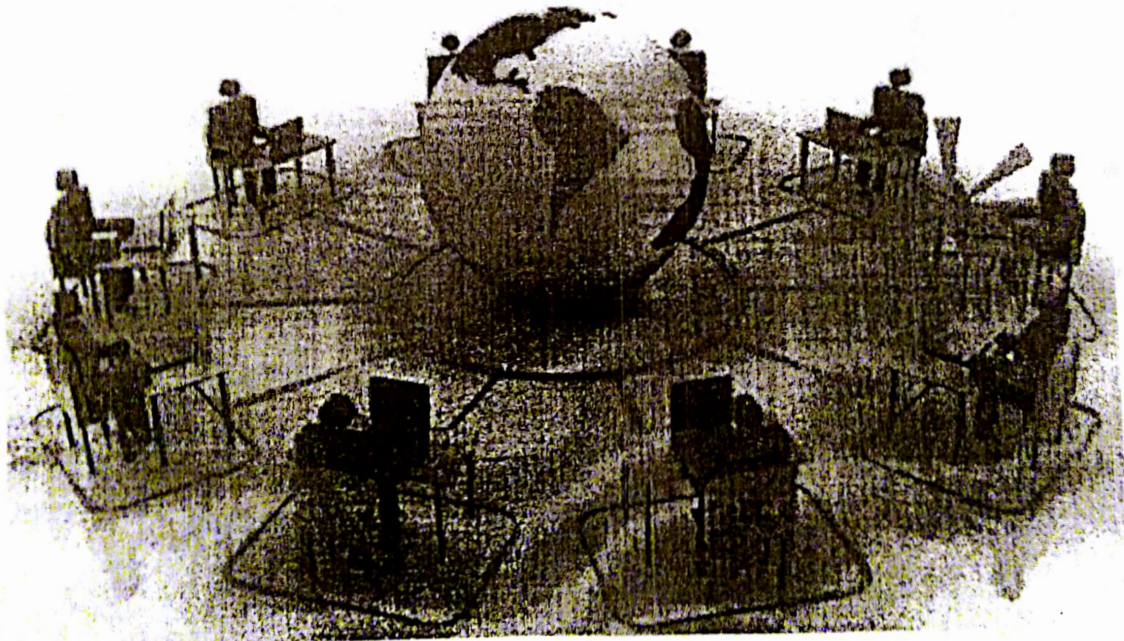

This has been prepared for the use of marking examiners. Changes would be made according to the views presented at the Chief/Assistant Examiners' meeting.

Amendments to be included.

ICnotes.org

Information and Communication Technology
Paper I
2017

| Q. No. | Answer | Q. No. | Answer | Q. No. | Answer | Q. No. | Answer | Q. No. | Answer |
|--------|--------|--------|--------|--------|--------|--------|--------|--------|--------|
| 1. | 5 | 11. | 2 | 21. | 3 | 31. | 4 | 41. | 5 |
| 2. | 1 | 12. | 4 | 22. | 4 | 32. | 1 | 42. | 2 |
| 3. | 5 | 13. | All | 23. | 1 | 33. | 5 | 43. | 4 |
| 4. | 4 | 14. | 1 | 24. | 3 | 34. | 4 | 44. | 5 |
| 5. | 3 | 15. | 5 | 25. | 5 | 35. | 5 | 45. | 2 |
| 6. | 1 | 16. | 4 | 26. | 2, 4 | 36. | 5 | 46. | 3 |
| 7. | 5 | 17. | 5 | 27. | 1 | 37. | 3 | 47. | 5 |
| 8. | All | 18. | 3 | 28. | 5 | 38. | 3 | 48. | 3 |
| 9. | 1 | 19. | 4 | 29. | 2 | 39. | 5 | 49. | 5 |
| 10. | 5 | 20. | 3 | 30. | 2 | 40. | 2 | 50. | 3 |

Information and Communication Technology (20)

Paper II Part A

2017

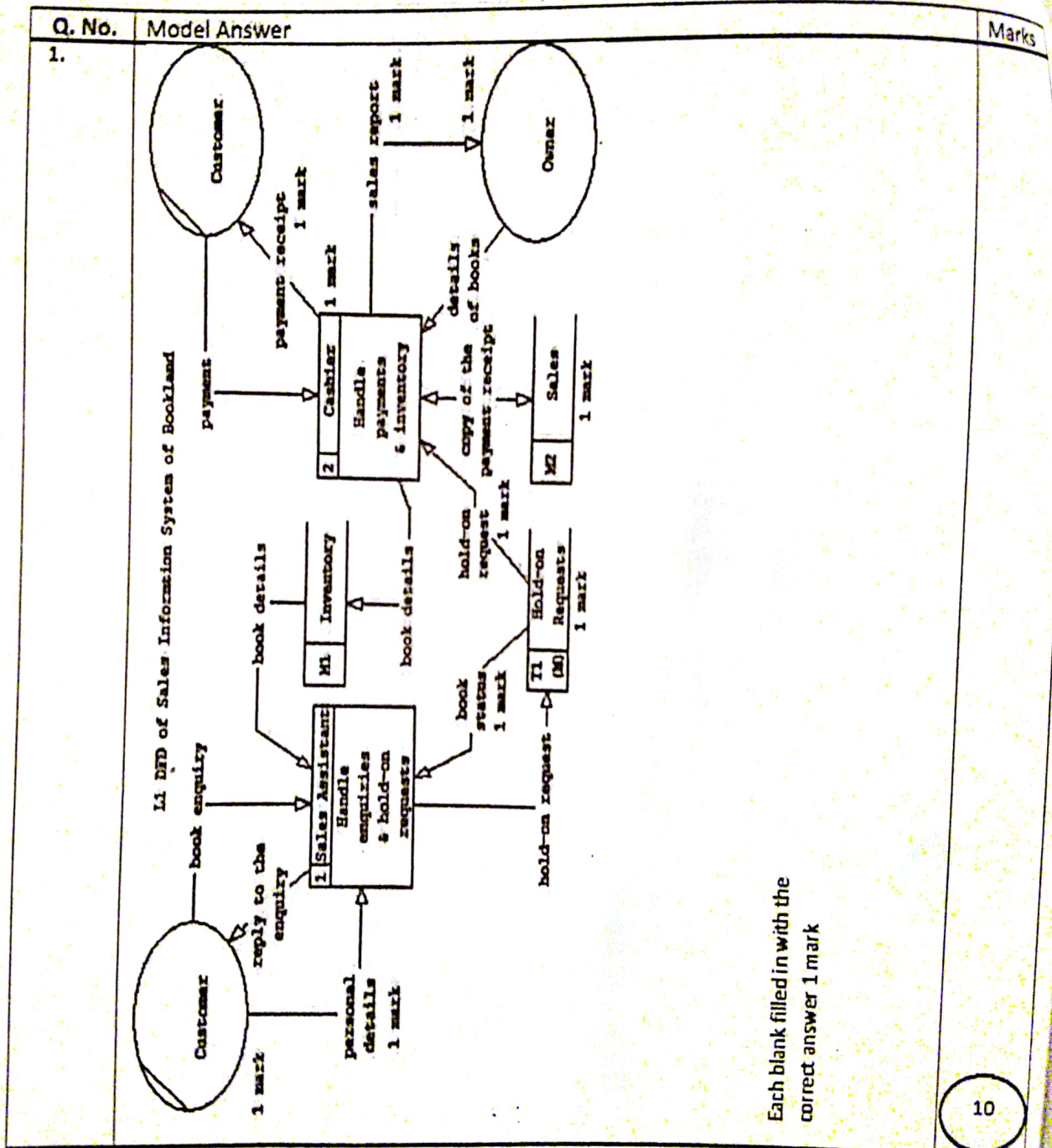

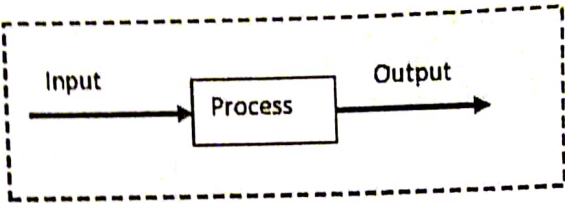
| | | |
|-------------------|--|--------------------------------------|
| | <p>update student set address = '13, School Lane, Jaffna' where student_no = '10001' } 1mark 2 (Note: The = sign only works for varchar type attributes)</p> <p>Or</p> <p>update student set address = '13, School Lane, Jaffna' } 1mark 2 (Assumption: Only one student record in the database) } 1mark</p> | <p>3</p> |
| <p>4.(a).(i)</p> |  <p style="text-align: center;">System boundary</p> <p>If not to write they we don't write system boundary If not to write they should write</p> | <p>1</p> |
| <p>4.(a).(ii)</p> | <p>In closed system both Input and output are available within the system. ^{system boundary}</p> <p>Or</p> <p>A sentence with the same meaning</p> | <p>5 or 0 4 5</p> |
| <p>4.(b)</p> | <p>person(NICNo) mobilePhone(TelephoneNo, NICNo)</p> <p>Each correct relation with attributes 1 mark Each primary key 1 mark (only if the relation is correct)</p> <p>OR</p> | <p>2 2 4</p> |

If they have only table (1)
primary key is there then
we will give (2)
7

Small correct (1)
without any other table.

Information and Communication Technology (20)
Paper II Part B
2017

| Q. No. | Model Answer | Marks | | | | | | | | | | | | | | | | | | | | | | | | | | | | | | | | | | | | |
|--|---|-------------|---|---|---|---|---|---|---|---|---|---|---|---|---|---|---|---|---|---|---|---|---|---|---|---|---|---|---|---|---|---|---|---|---|---|---|-----|
| 1.(a) | Air-conditioner (Q) [Define output] | 1 | | | | | | | | | | | | | | | | | | | | | | | | | | | | | | | | | | | | |
| | <table border="1" style="display: inline-table; border-collapse: collapse;"> <tr><td>A</td><td>B</td><td>C</td><td>Q</td></tr> <tr><td>0</td><td>0</td><td>0</td><td>0</td></tr> <tr><td>0</td><td>0</td><td>1</td><td>0</td></tr> <tr><td>0</td><td>1</td><td>0</td><td>1</td></tr> <tr><td>0</td><td>1</td><td>1</td><td>0</td></tr> <tr><td>1</td><td>0</td><td>0</td><td>0</td></tr> <tr><td>1</td><td>0</td><td>1</td><td>0</td></tr> <tr><td>1</td><td>1</td><td>0</td><td>1</td></tr> <tr><td>1</td><td>1</td><td>1</td><td>0</td></tr> </table> [Correct input columns + 8 combinations] | A | B | C | Q | 0 | 0 | 0 | 0 | 0 | 0 | 1 | 0 | 0 | 1 | 0 | 1 | 0 | 1 | 1 | 0 | 1 | 0 | 0 | 0 | 1 | 0 | 1 | 0 | 1 | 1 | 0 | 1 | 1 | 1 | 1 | 0 | 1+1 |
| | A | B | C | Q | | | | | | | | | | | | | | | | | | | | | | | | | | | | | | | | | | |
| | 0 | 0 | 0 | 0 | | | | | | | | | | | | | | | | | | | | | | | | | | | | | | | | | | |
| | 0 | 0 | 1 | 0 | | | | | | | | | | | | | | | | | | | | | | | | | | | | | | | | | | |
| | 0 | 1 | 0 | 1 | | | | | | | | | | | | | | | | | | | | | | | | | | | | | | | | | | |
| | 0 | 1 | 1 | 0 | | | | | | | | | | | | | | | | | | | | | | | | | | | | | | | | | | |
| | 1 | 0 | 0 | 0 | | | | | | | | | | | | | | | | | | | | | | | | | | | | | | | | | | |
| | 1 | 0 | 1 | 0 | | | | | | | | | | | | | | | | | | | | | | | | | | | | | | | | | | |
| | 1 | 1 | 0 | 1 | | | | | | | | | | | | | | | | | | | | | | | | | | | | | | | | | | |
| 1 | 1 | 1 | 0 | | | | | | | | | | | | | | | | | | | | | | | | | | | | | | | | | | | |
| <table border="1" style="display: inline-table; border-collapse: collapse;"> <tr><td>A</td><td>B</td><td>C</td><td>Q</td></tr> <tr><td>0</td><td>0</td><td>0</td><td>0</td></tr> <tr><td>0</td><td>0</td><td>1</td><td>0</td></tr> <tr><td>0</td><td>1</td><td>0</td><td>1</td></tr> <tr><td>0</td><td>1</td><td>1</td><td>0</td></tr> <tr><td>1</td><td>0</td><td>0</td><td>0</td></tr> <tr><td>1</td><td>0</td><td>1</td><td>0</td></tr> <tr><td>1</td><td>1</td><td>0</td><td>1</td></tr> <tr><td>1</td><td>1</td><td>1</td><td>0</td></tr> </table> [Correct output column] | A | B | C | Q | 0 | 0 | 0 | 0 | 0 | 0 | 1 | 0 | 0 | 1 | 0 | 1 | 0 | 1 | 1 | 0 | 1 | 0 | 0 | 0 | 1 | 0 | 1 | 0 | 1 | 1 | 0 | 1 | 1 | 1 | 1 | 0 | 2 | |
| A | B | C | Q | | | | | | | | | | | | | | | | | | | | | | | | | | | | | | | | | | | |
| 0 | 0 | 0 | 0 | | | | | | | | | | | | | | | | | | | | | | | | | | | | | | | | | | | |
| 0 | 0 | 1 | 0 | | | | | | | | | | | | | | | | | | | | | | | | | | | | | | | | | | | |
| 0 | 1 | 0 | 1 | | | | | | | | | | | | | | | | | | | | | | | | | | | | | | | | | | | |
| 0 | 1 | 1 | 0 | | | | | | | | | | | | | | | | | | | | | | | | | | | | | | | | | | | |
| 1 | 0 | 0 | 0 | | | | | | | | | | | | | | | | | | | | | | | | | | | | | | | | | | | |
| 1 | 0 | 1 | 0 | | | | | | | | | | | | | | | | | | | | | | | | | | | | | | | | | | | |
| 1 | 1 | 0 | 1 | | | | | | | | | | | | | | | | | | | | | | | | | | | | | | | | | | | |
| 1 | 1 | 1 | 0 | | | | | | | | | | | | | | | | | | | | | | | | | | | | | | | | | | | |
| $Q = A'.B.C' + A.B.C'$ $= B.C'.(A'+A)$ $= B.C'$ | [Boolean expression] [At least one correct rule] [Solution] | 3 1 1 | | | | | | | | | | | | | | | | | | | | | | | | | | | | | | | | | | | | |
| <div style="display: flex; align-items: center;"> <div style="margin-right: 20px;"> <p>distributive law complement law</p> </div> <div style="border-left: 1px dashed black; padding-left: 10px;"> </div> </div> | [Circuit] | 3 or 0 | | | | | | | | | | | | | | | | | | | | | | | | | | | | | | | | | | | | |
| Optional | | 13 | | | | | | | | | | | | | | | | | | | | | | | | | | | | | | | | | | | | |
| 1.(b) | Yes. Input that represents Switch (A) is not in the Boolean expression/circuit/solution. Therefore, it is not required for the operation of the air-conditioner. | 1 1 2 | | | | | | | | | | | | | | | | | | | | | | | | | | | | | | | | | | | | |

2. Assume that the entire private address range is used (it can be any range)

Since there are 4 subnets, it is required to divide the address range into 4 segments.

For this, add two more bits to the subnet mask.

Subnet mask length becomes 10.

11111111.11000000.00000000.00000000

Therefore, the 4 subnets would be:

- 1. 00001010.00000000.00000000.00000000 = 10.0.0.0/10
 - 2. 00001010.01000000.00000000.00000000 = 10.64.0.0/10
 - 3. 00001010.10000000.00000000.00000000 = 10.128.0.0/10
 - 4. 00001010.11000000.00000000.00000000 = 10.192.0.0/10
- [1 x 4] 4

(if they decide to use /24 ranges, they should assume that 255 addresses are enough for each subnet. Then they should show the selection of /24 ranges.)

Note: If the selected ranges are shown in the diagram these 4 marks can be given

Needed Devices: 05 Hubs, Switch, Router, Firewall, Web Server, Mail Server, Proxy server, Application Server.

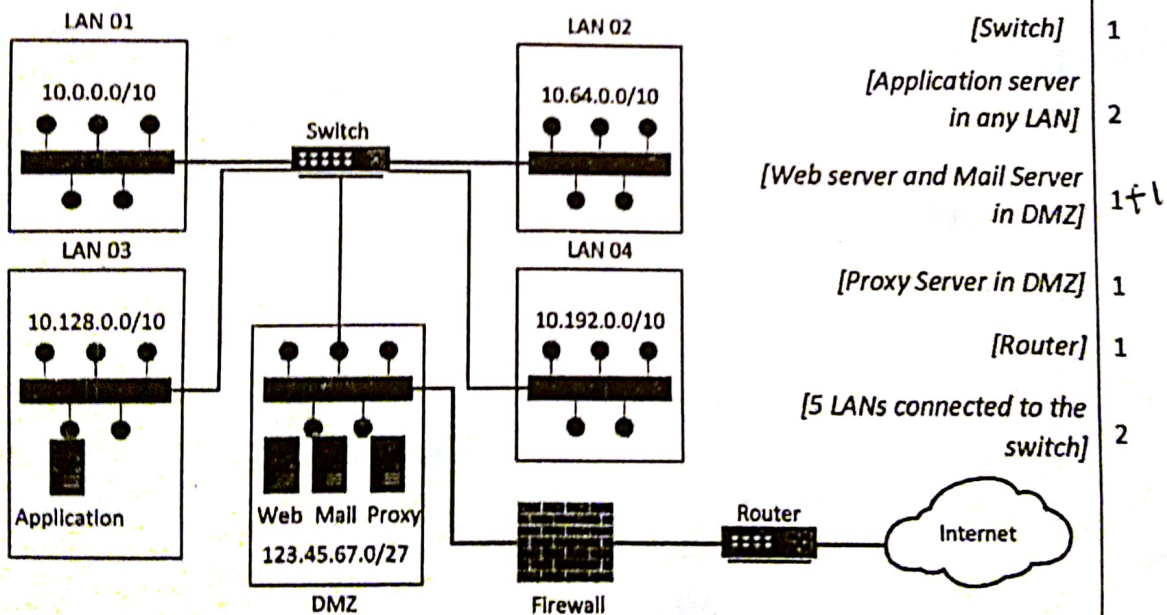

Since any computer in any subnetwork can access resources in all subnetworks, the application server can be established in any subnetwork. Since it is for internal clients, it should not be located in the DMZ.

Note: 1.Proxy Server could be directly connect to the Switch

When the packet goes to the proxy server, its source IP address is rewritten with the public IP address of proxy server. 2

| | | | |
|-------|--|--------|---|
| 3.(a) | G2C or Government to Consumer/ <i>Citizen</i> | 3 | 3 |
| 3.(b) | G2B or G2E, It is a service provided in online by the Government to Business or Employees. | 1 1 | 2 |
| 3.(c) | Because it is a service provided by business to government. Therefore it is B2G. | 4 1 | 5 |
| 3.(d) | Law: To prepare fine calculations mechanism according to the (<i>criticality of the identified place</i>). Epidemic Control Division: (To develop formula to measure the <i>criticality of the identified place related to dengue breeding</i>). | 3 2 | 5 |

| | | |
|--------------|--|---|
| <p>4.(a)</p> | <pre> graph TD Start([start]) --> Read[/Read house hold no (hno) Past Reading (rpast) Present Reading (rpresent)/] Read --> Calc[unitsUsed = rpresent - rpast payment = 0] Calc --> Cond{unitUsed > 64?} Cond -- no --> Calc2[payment = unitsUsed * 5.00] Cond -- yes --> Calc3[payment = 64 * 5.00 + (unitUsed - 64) * 10.00] Calc2 --> Print[/print payment/] Calc3 --> Print Print --> End([end]) </pre> | <p>[Input] 1</p> <p>[Calculation] 1</p> <p>[Condition] 1</p> <p>[Calculation] 1</p> <p>[Calculation] 1</p> <p>[Print] 1</p> <p>[Correct diagram] 1</p> <p style="text-align: center;">7</p> |
|--------------|--|---|

| | | |
|--------------|---|--|
| <p>4.(b)</p> | <pre> hno = input("Enter house hold number ->") rpast = int(input("Last meter reading ->")) rpresent = int(input("Present meter reading ->")) unitsUsed = rpresent - rpast if unitsUsed > 64: payment = 64 * 5.00 + (unitsUsed - 64) * 10.00 else: payment = unitsUsed * 5.00 print(payment) </pre> <p>Assumptions : The assumptions are based on the programme</p> <ul style="list-style-type: none"> The present meter reading is higher than the past meter reading Integer values should be entered for present and past meter readings | <p>[Input] 1</p> <p>[if with correct computation] 1</p> <p>[else with correct computation] 1</p> <p>[Print] 1</p> <p style="text-align: center;">4</p> |
|--------------|---|--|

| | | |
|--------------|--|--|
| <p>4.(c)</p> | <pre> def writetofile(houseNo,rpast,rpresent,charge): f = open("deb.txt","a") print(houseNo,rpast,rpresent,charge,file=f,sep=",") f.close() Note: f.write(str(houseNo)+ " " + str(rpast)+ " " + str(rpresent) + " " + str(charge)) f.write("%s %s %s %s" % (houseNo,rpast,rpresent,charge)) </pre> | <p>1</p> <p>1</p> <p>1</p> <p>1</p> <p style="text-align: center;">4</p> |
|--------------|--|--|

5.

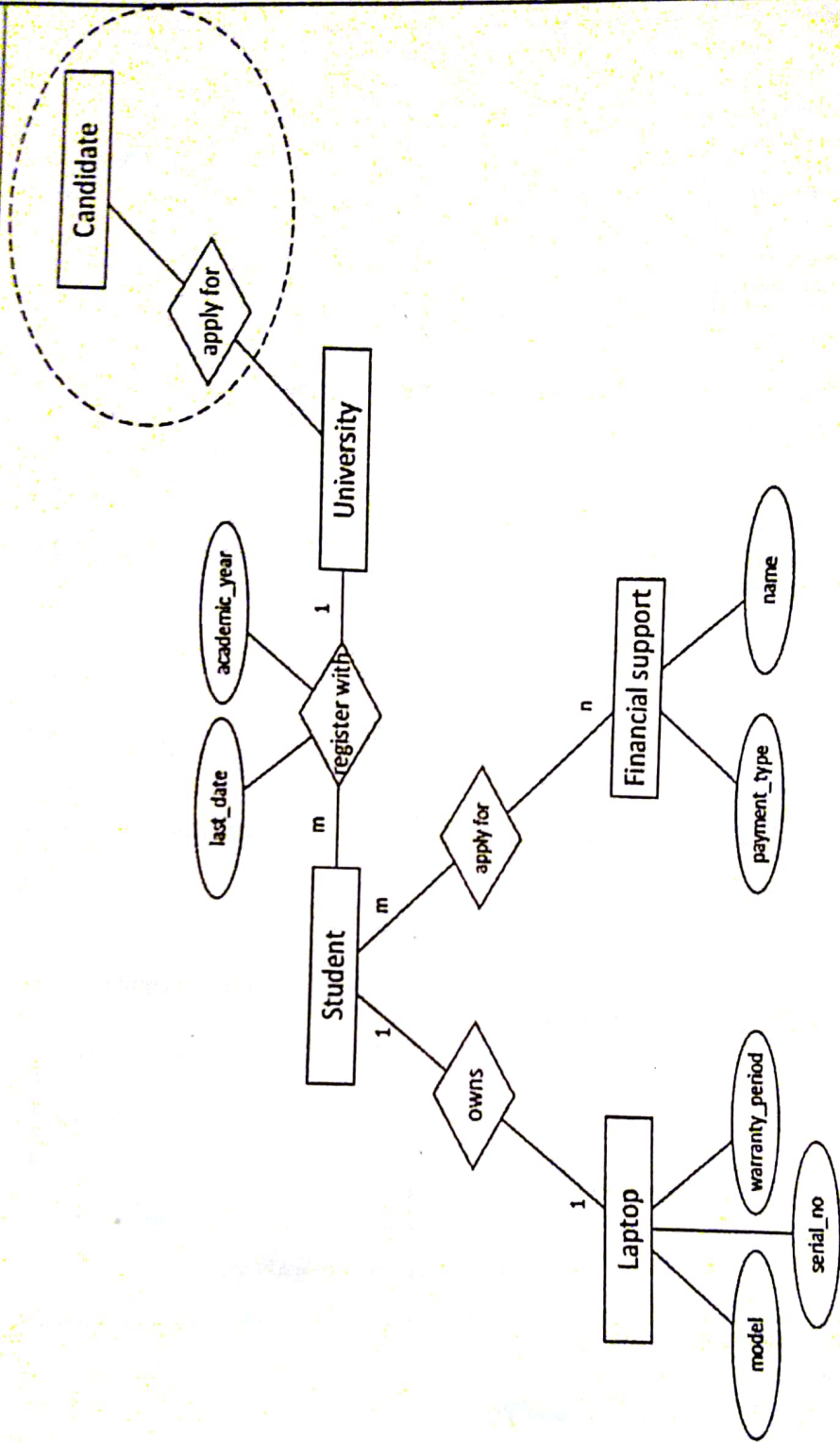

Entities 1x 4

Relation with correct cardinality 1x3

Acceptable attributes attached to any entity 1 mark each maximum 5

Attributes attached to relation 1x2

Circled section

4
3
5
2
1

| | | | | | | |
|---|--|---|---|---|---|---|
| 6.(a) | <pre> <html > <head> <meta charset="utf-8"> <title>Information</title> <style> OR <style type="text/css"> li{ font-family: calibri; font-size: 14pt; color: red; list-style: square; } </style> OR <link rel="stylesheet" type="text/css" href="def.css"> </head> <body> <h1>Student Art Competition</h1> <h2>Theme: Litter on the environment </h2> <h3>PRIZES</h3> 1st place Rs. 10,000/= 2nd place Rs. 7,500/= 3rd place Rs. 5,000/= <h3>ENTRY FORM</h3> <p>Please fill and submit this online entry form to enter the competition. </P> </body> </html> </pre> | <p style="text-align: center;">[or "calibri"]</p> <p style="text-align: center;">[or list-style-type]</p> <p style="text-align: center;">[At least 2 different levels]</p> | 4 | 2 | 1 | 2 |
| <div style="border: 1px solid black; border-radius: 50%; width: 30px; height: 30px; display: flex; align-items: center; justify-content: center; margin: 0 auto;">9</div> | | | | | | |

5.(b)

```
<html >
  <head>
    <meta charset="utf-8">
    <title>Entry Form</title>
  </head>

  <body>
    <h1>Art Competition Online Entry Form 2017</h1>
    <h3>Theme: Litter on the environment</h3>
    <form method = "get" action = "script.php">                                [ <form> and </form> ] 1
      Name: <input type="text" name="name" >
      <p>Gender:
        <input type="radio" name="sex" value="male" > Male
        <input type="radio" name="sex" value="female" > Female } 1
      </p>

      <p>Grade Category . . .
      <select name="ageGroup">
        <option value="g1">Grade 1 - 2</option>
        <option value="g2">Grade 3 - 6</option>
        <option value="g3">Grade 7 - 10</option>
        <option value="g4">Grade 11 - 13</option>
      </select></p> } 1

      <p>Art media: </p>
      <input type="checkbox" name="media1" value="Colour" >
        Water Colours
      <br />
      <input type="checkbox" name="media2" value="Pencils" >
        Colour Pencils
      <br />
      <input type="checkbox" name="media3" value="Crayon" > Crayon
      <br />
      <input type="checkbox" name="media4" value="Chalk" > Chalk } 1

      <p><input type = "reset" value = "Clear your Entries"></p> 1

      <p><input type="submit" value="Submit" ></p> 1

    </form>
  </body>
</html>
```

6

ICT විෂයට අදාළ සියලුම ඉගෙනුම්
උපකාරක එකම තැනකින්

ICT notes.org + **VLE**

පාඩම්වල වලට
අදාළ සටහන්

පසුගිය විභාග
ප්‍රශ්න පත්‍ර

තෙරහුරු හා වාර
විභාග ප්‍රශ්න පත්‍ර

CLICK HERE TO DOWNLOAD

